

The Magnum is Supra's most durable mechanical KeyBox in the automotive market. Made from non-corrosive zinc alloy, the Magnum's sidewalls are 33% thicker than previous KeyBoxes.

Utilizing the proven Title™ lock and key system which permits only authorized access, the Magnum is completely compatible with all of Supra's existing KeyBoxes.

Features

- Greater storage capacity for multiple keys and remote devices
- Improved tamper resistance
- Improved durability
- Secured Title™ lock
- Personalized nameplates available

Benefits

- Service customers faster
- Improve efficiency of operations
- Salespeople stay with prospects at all times and can easily move with them from vehicle to vehicle

Magnum was designed in response to the demand for a bigger and stronger KeyBox. Re-engineering the cam of the lock increased durability and improved the KeyBox's resistance to tampering. The new design features a recessed lid which also adds to the security and durability.

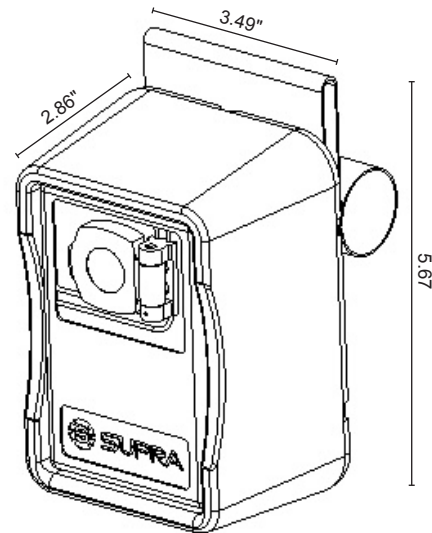

The durable Magnum keeps keys with the vehicle

U.S.A.
4001 Fairview Industrial Dr. SE
Salem, OR USA 97302
T 800.547.0252
F 503.375.9381

Canada
850 Industrial Ave. Unit 5
Ottawa, Ontario K1G 4K2
800.267.6317
T 613.737.3623
F 613.737.5517

© 2010 UTC Fire & Security.
All rights reserved.



Supra Magnum: P/N 001288



Industrial Magnum: P/N 001287
A permanent-mount version is available for those applications where window access is impractical.

